

Assembly Instructions

FILTERCREEL 3

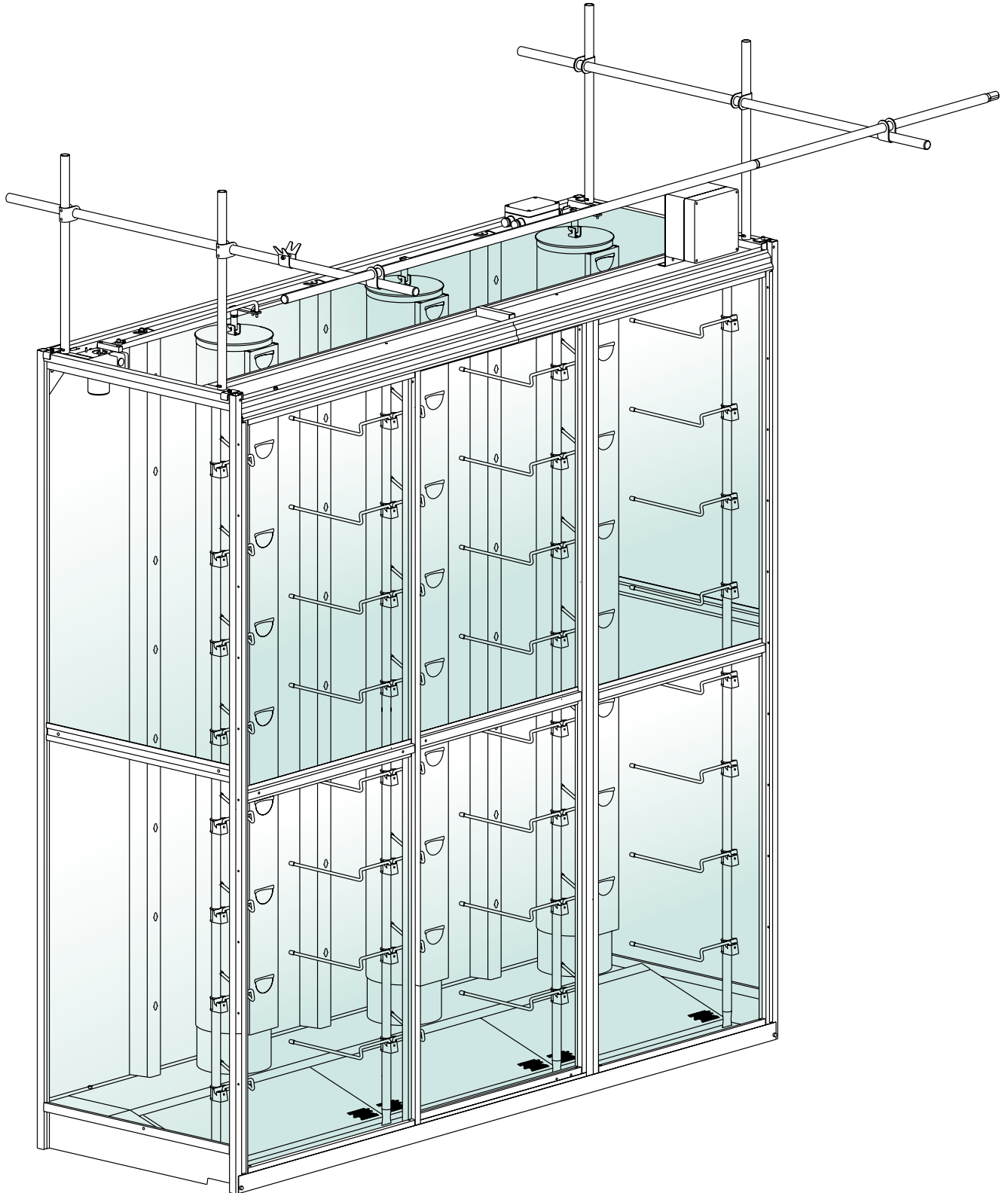

Foreword

We are very pleased that you have chosen a product from MEMMINGER-IRO. The more familiar you are with this product, the better the results you will be able to achieve with it.

Therefore we request:

Read through these operating instructions before commissioning the product. They contain important information and notes, which must be observed during operation of the device.

Table of contents

Foreword	1
Table of contents	1
Safety notes	2
Explanation of Symbols	2
Safety notes for Assembly and Operation	2
Function	3
Function	3
Versions	3
Component parts	4
Preassembly	5
Extension rail	5
Basic support	5
Basic- and extension frame	5
Drive motor	5
Air hoses	6
Assembly	7
Fan unit	7
Tube channel	7
Side pieces and plate	8
Creel	9
Tube support	10
Backplate	11
Door assembly	12
Placing the yarn tubes	14
Air-Jet	15
Electrical connection	16
Technical data	18
Declaration of incorporation and conformity	19

Explanation of Symbols



ATTENTION!

This symbol indicates that the instruction to which it refers must be followed exactly in order to avoid damage to the product or personnel.



NOTE!

Particular details with regard to economical use of the FILTERCREEL 3.

Safety notes for Assembly and Operation



ATTENTION!

The FILTERCREEL is designed exclusively for supplying yarns to textile machines. Any alternative or additional usage will be classed as improper. MEMMINGER-IRO accepts no liability for any damage resulting from such improper use. The risk is borne solely by the user.

Connection of the FILTERCREEL and all work on the electrical system may only be carried out by a qualified electrician, in accordance with electrical engineering standards.

The 400 V AC 3 phase power supply comes from the machine and it must be possible to turn it off using the knitting machine's main switch. No voltage must be present in the connection box when the knitting machine is turned off.

A 24V control voltage is required to operate the FILTERCREEL. This control voltage may only be present when the machine is running.

The housing cover of the power supply must be closed at commissioning.

Cleaning work is not permitted while fans are running. When working inside the FILTERCREEL, turn off the main switch of the knitting machine and secure it against being turned on again.

Even for a slight change of location, the power supply must be disconnected from the knitting machine. The power supply should then be properly connected again before restarting.

We hereby give notice that we will accept no liability for damages and operating defects resulting from incorrect operation or improper handling of the equipment.

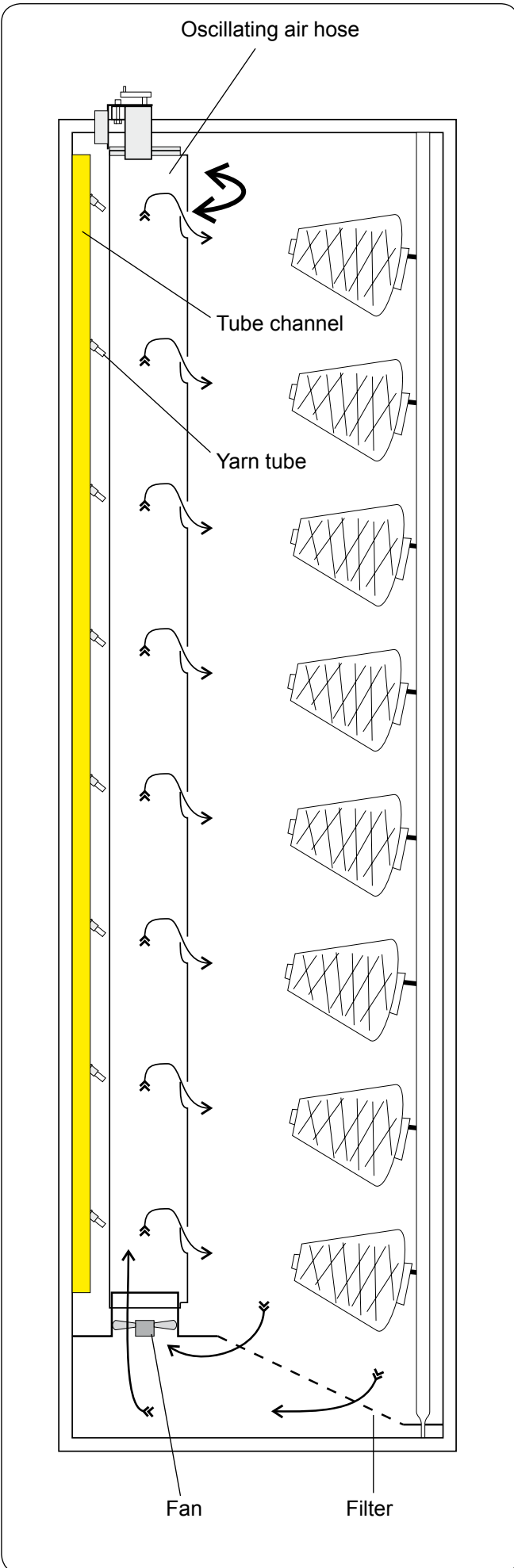

Function

The FILTERCREEL 3 is an enclosed side creel for supplying the yarns to textile machines. The yarn packages are situated inside a closed cabinet, with an air blowing and circulation system. Air is blown onto the front of each package from ventilator slots attached to an oscillating air hose. In this way the running yarn packages, reserve packages and their tying-in yarn tails are kept free of fly and lint build up. All the fly is blown off and collected on the filter located at the bottom of the FILTERCREEL 3, and can easily be removed. Yarn paths from FILTERCREEL 3 to the machine are through yarn tubes.

Versions

The FILTERCREEL 3 is available with 2 to 6 sections, each for 6 or 8 double packages.

Yarn tubes are available in either plastic or aluminium.

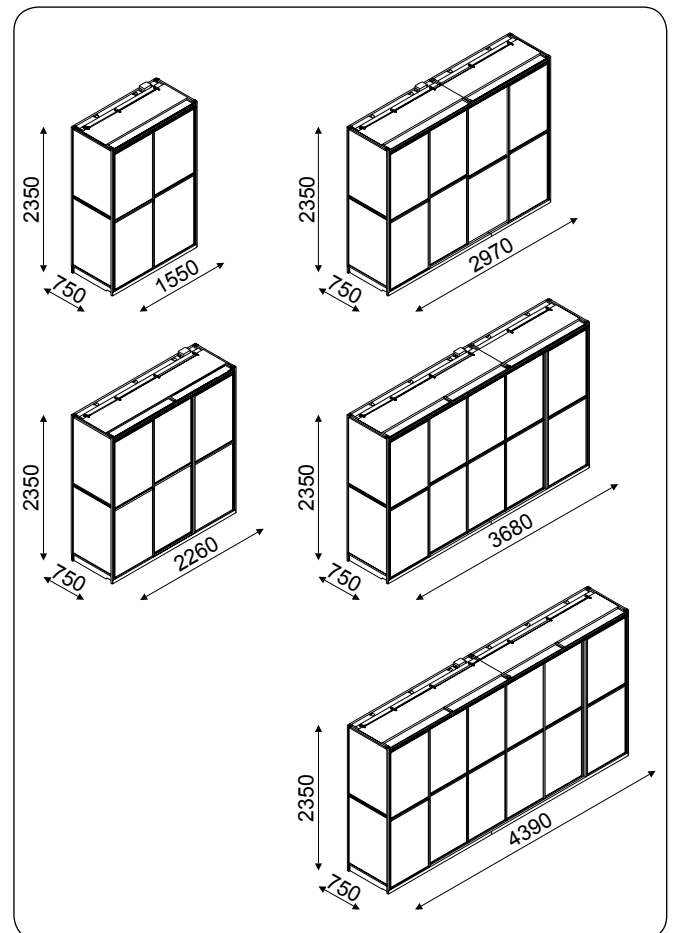

Component parts

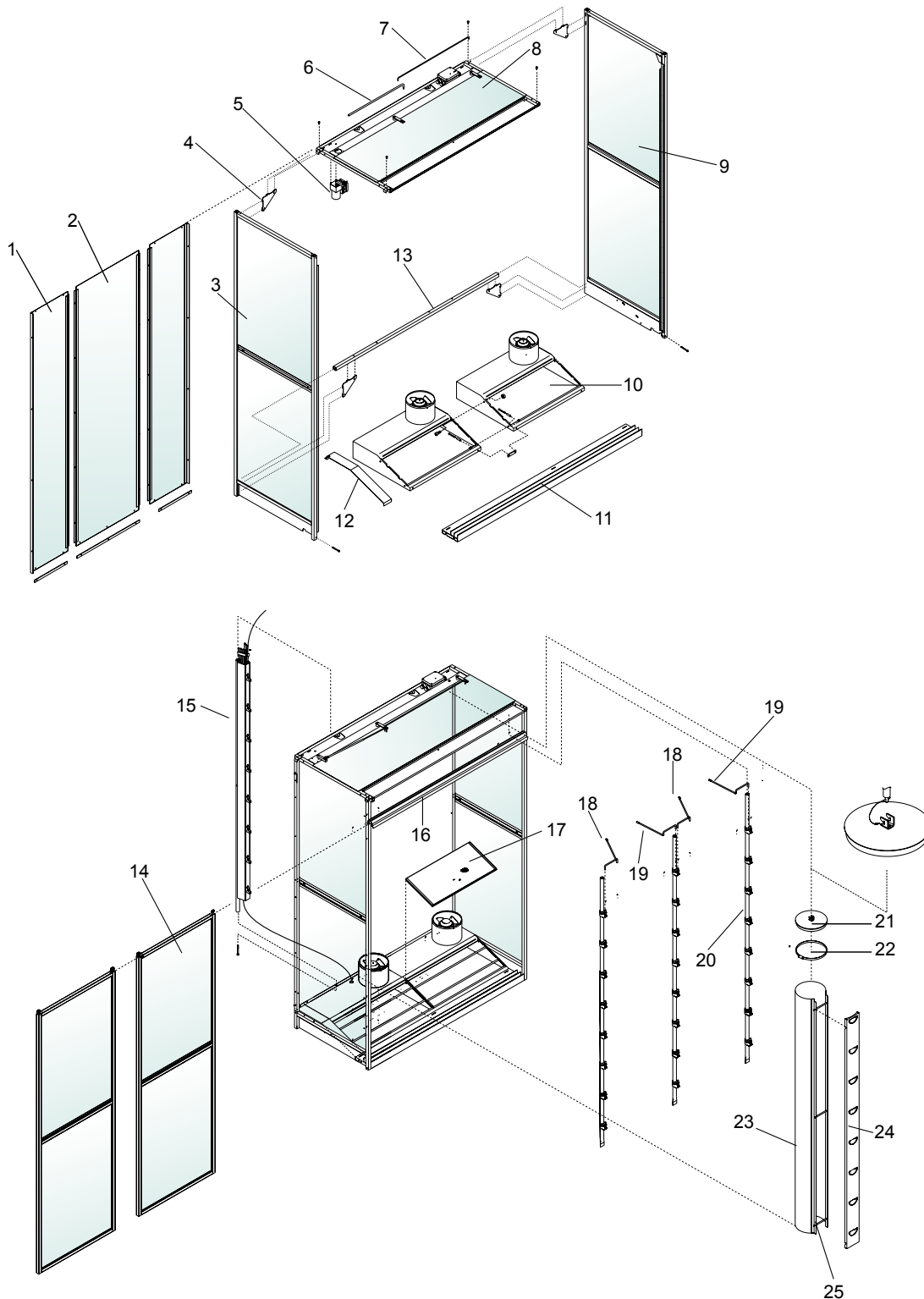

- | | | |
|---|---|----------------------------|
| 1 - backplate segment small | 9 - side panel, right hand | 17 - filter cartridge |
| 2 - backplate segment large | 10 - fan unit | 18 - bobbin bar right |
| 3 - side panel, left hand | 11 - rail for 2 sections/
3 sections | 19 - bobbin bar left |
| 4 - corner amplification | 12 - base plate | 20 - bobbin support |
| 5 - gear motor | 13 - basic support | 21 - end plate with holder |
| 6 - drive rod | 14 - sliding door | 22 - worm drive clamp |
| 7 - tie rod | 15 - tube duct | 23 - air hose jacket |
| 8 - basic frame top,
2 sections/3 sections | 16 - extension rail | 24 - shield |
| | | 25 - distance bolt |

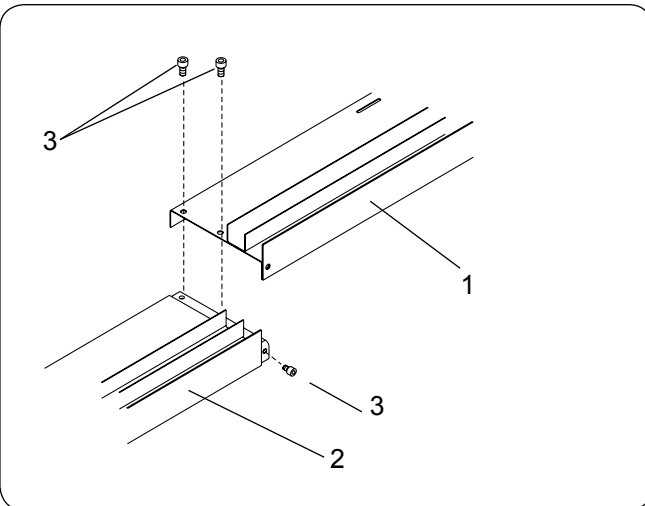

Extension rail

Connect extension rail (1*) to basic rail (2) using screws (3) (FILTERCREEL 3 with 4, 5 or 6 segments only).

- ▶ 3 cheese head screws, M6x10

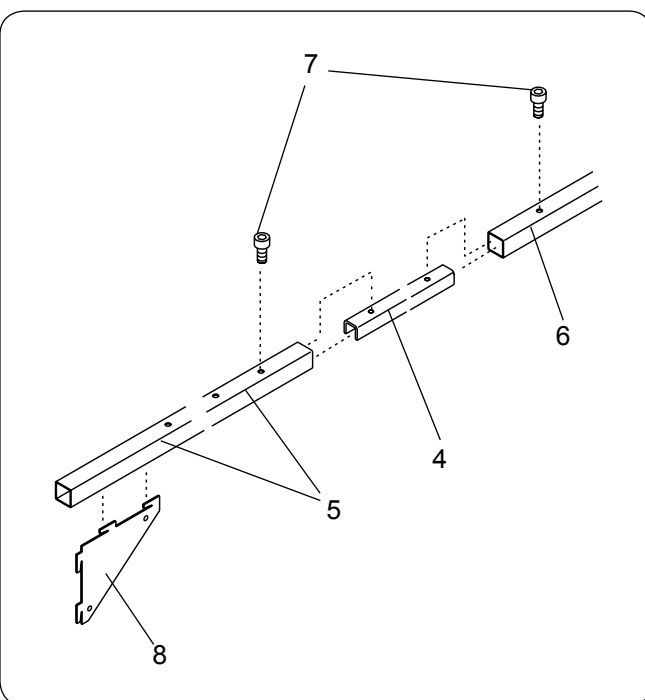

Basic support

Insert support connector (4) halfway into the basic support (5) and the extension support (6) and screw down (4, 5 and 6 segments only).

- ▶ 2 cheese head screws, M6x10 (7)
- ▶ Insert corner amplification (8) into the basic support

NOTE!
Holes have an asymmetrical bore! Large hole spacing to the rear!

Basic- and extension frame

Fix extension fitting into basic frame

- ▶ cheese head screws, M6x60 (9)
- ▶ washers A6.4 (10)
- ▶ nuts M6 (11)
- ▶ hexagon head cap screws M6x12 (12)

FILTERCREEL with 2 and 3 segments =

- ▶ 1 basic frame (13)

FILTERCREEL with 4 and 5 segments =

- ▶ 1 basic frame (13)
- ▶ 1 extension frame (14)
- ▶ 1 extension rail (15)

FILTERCREEL with 6 segments =

- ▶ 1 basic frame (13)
- ▶ 2 extension frames (14)
- ▶ 2 extension rails (15)

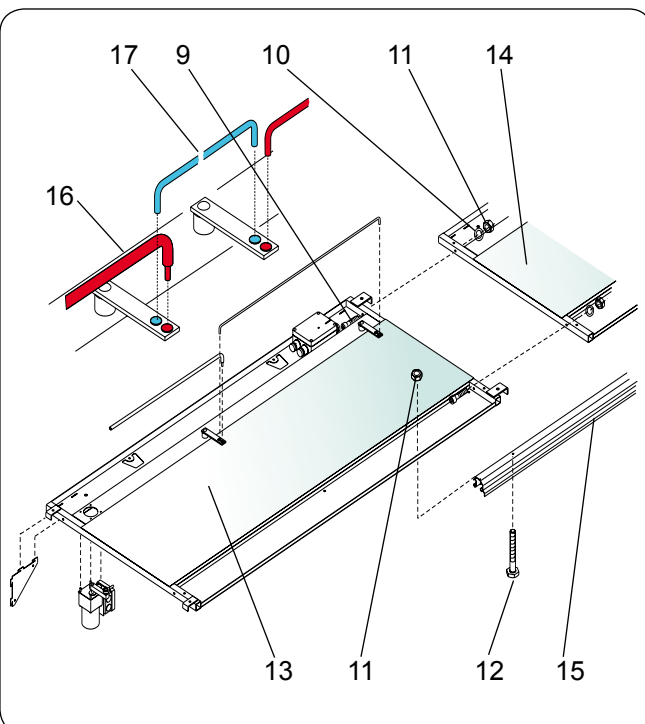

NOTE!
Fit extension rail to the basic or extension frame on the bottom of the device before assembling the basic or extension frame.

Drive motor

Insert drive motor into the basic frame from underneath and fix in place using nuts and M4 washers.

Insert drive rod (16) and connecting rod (17) into the basic frame lever from above and fix in place using spring washers.

Air hoses

The shape of the air hose (1) is maintained by the three distance bolts (2). At the top and bottom distance bolts, bushes (4) are screwed on, to provide the supports for the location of the shield (3).

- ▶ 4 cheese head screw M4x14 (5)
- ▶ 2 flat mushroom head screws M4x10 (6)

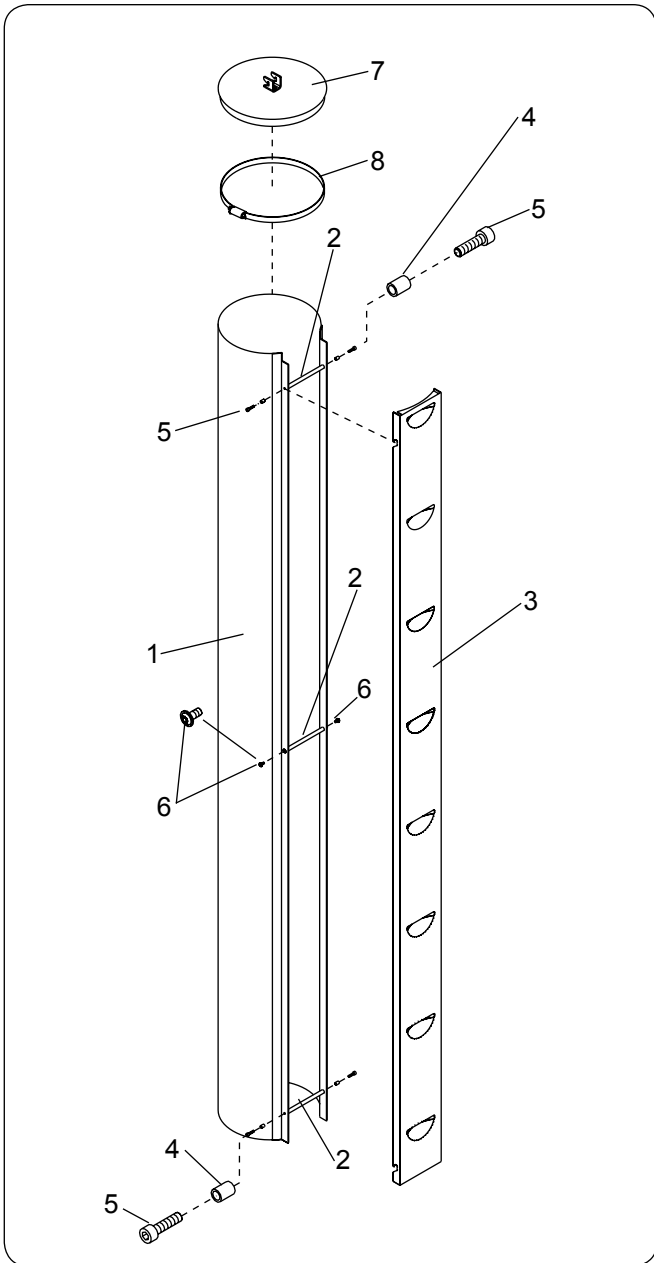

Fit the cover plate (7) in such a way that the suspension fitting is at 90° to the shield.

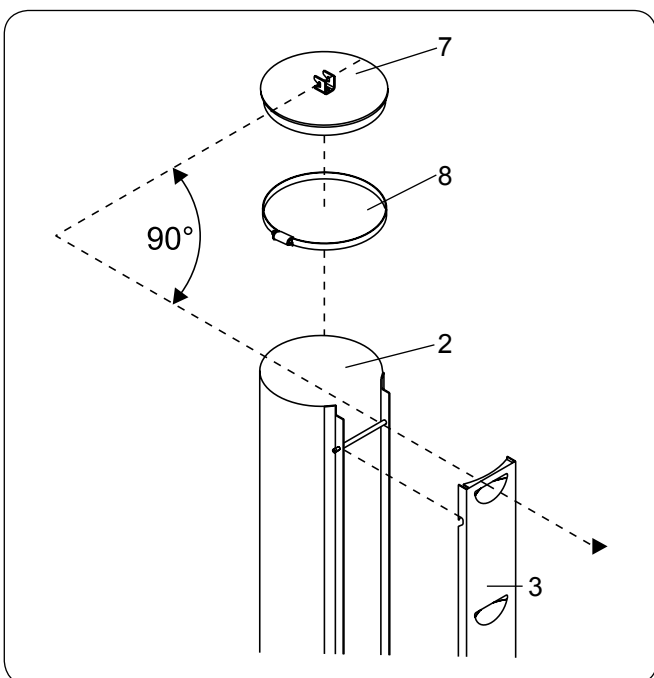

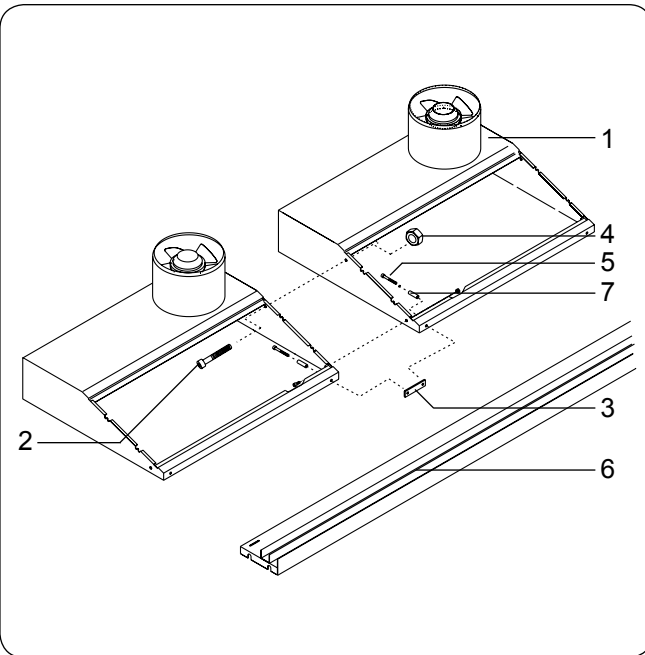

Fan unit

Position the fan units (1) side-by-side on the floor and connect them by means of the screws (2). Then, attach the terminal strip (3) onto the fan units.

- ▶ cheese head screws M6x10 (2)
- ▶ nuts M6 (4)
- ▶ cheese head screws M6x40 (5) for each basic rail (6)
- ▶ spacersleeves (7)
- ▶ terminal strip (3)

Then hang the basic rail (6) in the terminal strip.

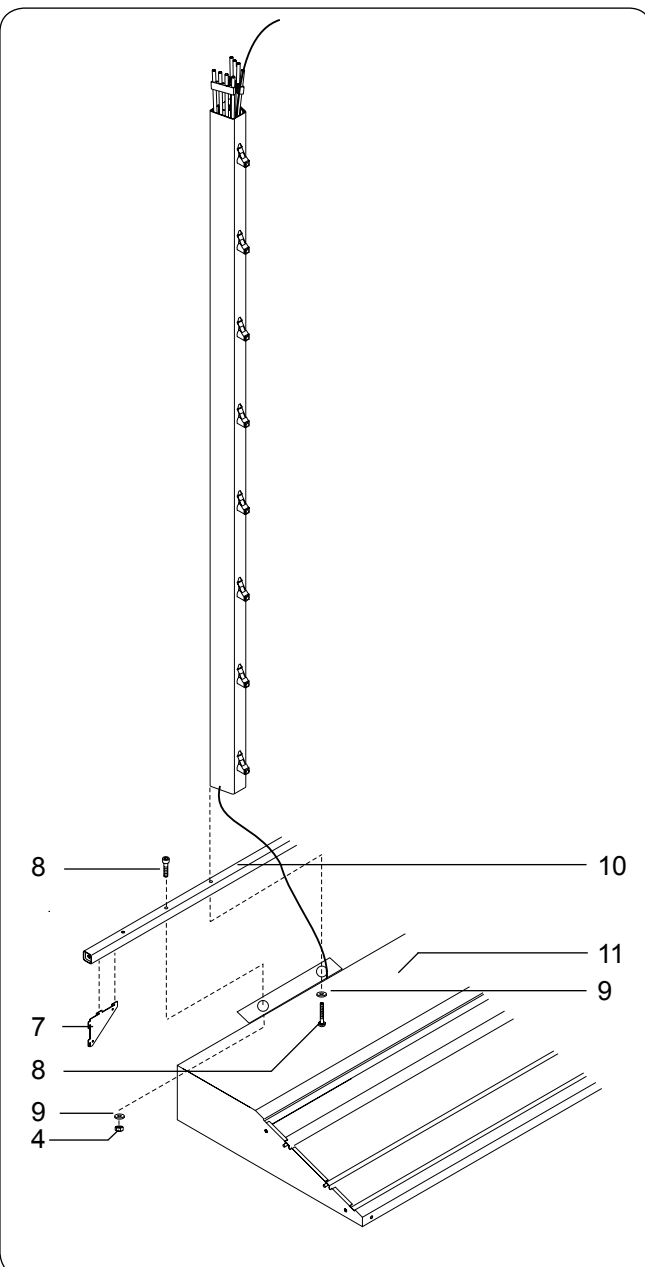

Tube channel

Insert corner amplification (7) into the support from underneath.

- ▶ cheese head screws M6x40 (8)
- ▶ washers Ø6 (9)
- ▶ nut M6 (4)
- ▶ corner amplification (7)

Screw the support (10) to the rear of the fan unit (11).

- ▶ cheese head screws M6x40 (8)
- ▶ washers Ø6 (9)



NOTE!

The tube duct accommodates the cable.

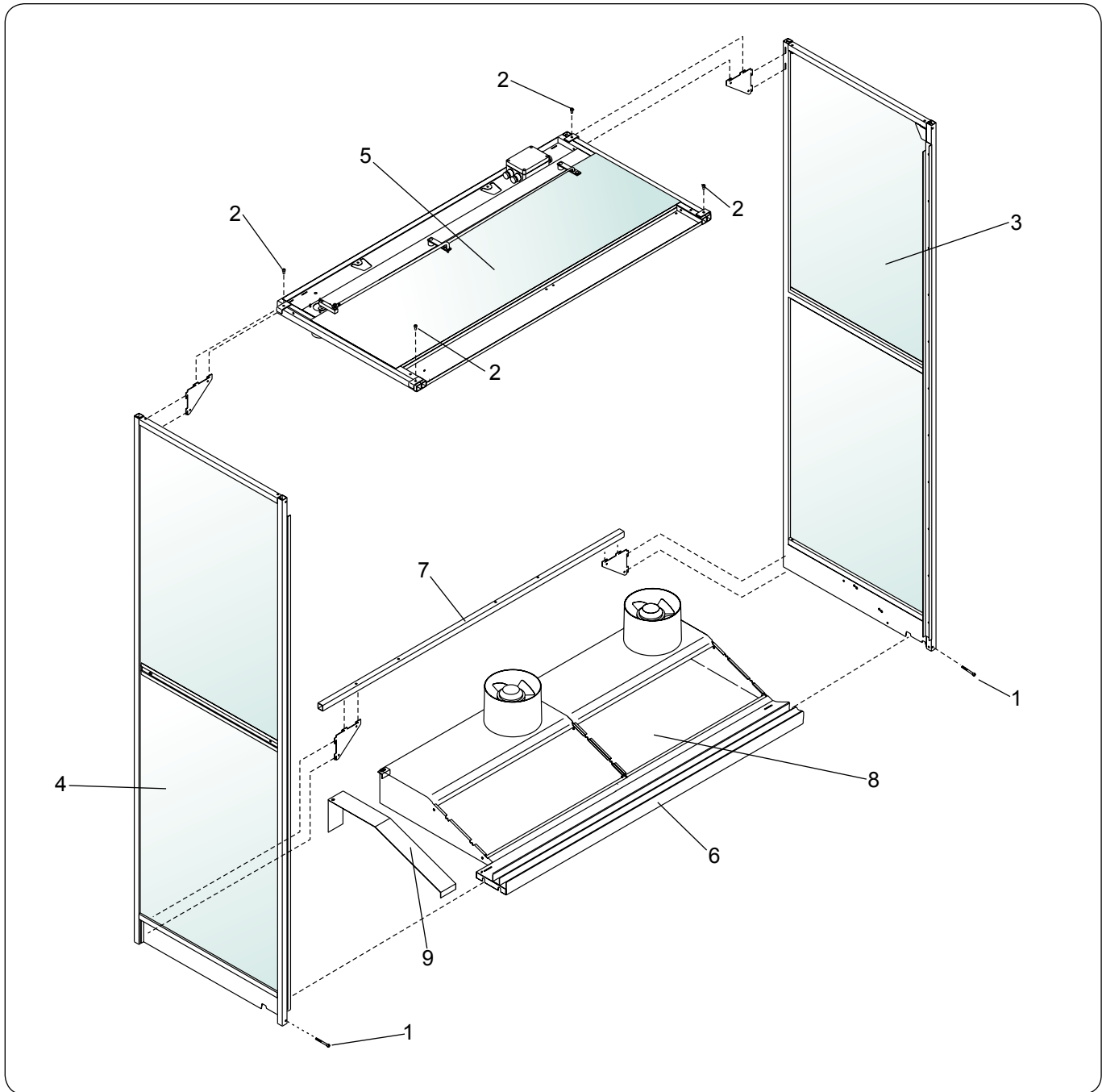

Side pieces and plate

- ▶ 2 cheese head screws M6x40 (1)
- ▶ 4 cheese head screws M6x40 (2)
- ▶ Right-hand side piece, complete (3)
- ▶ Left-hand side piece, complete (4)
- ▶ top basic frame (5) for 2 segments/3 segments
- ▶ bar (6) for 2 segments/3 segments
- ▶ rear support (7)
- ▶ fan unit (8)
- ▶ cover plate (9)

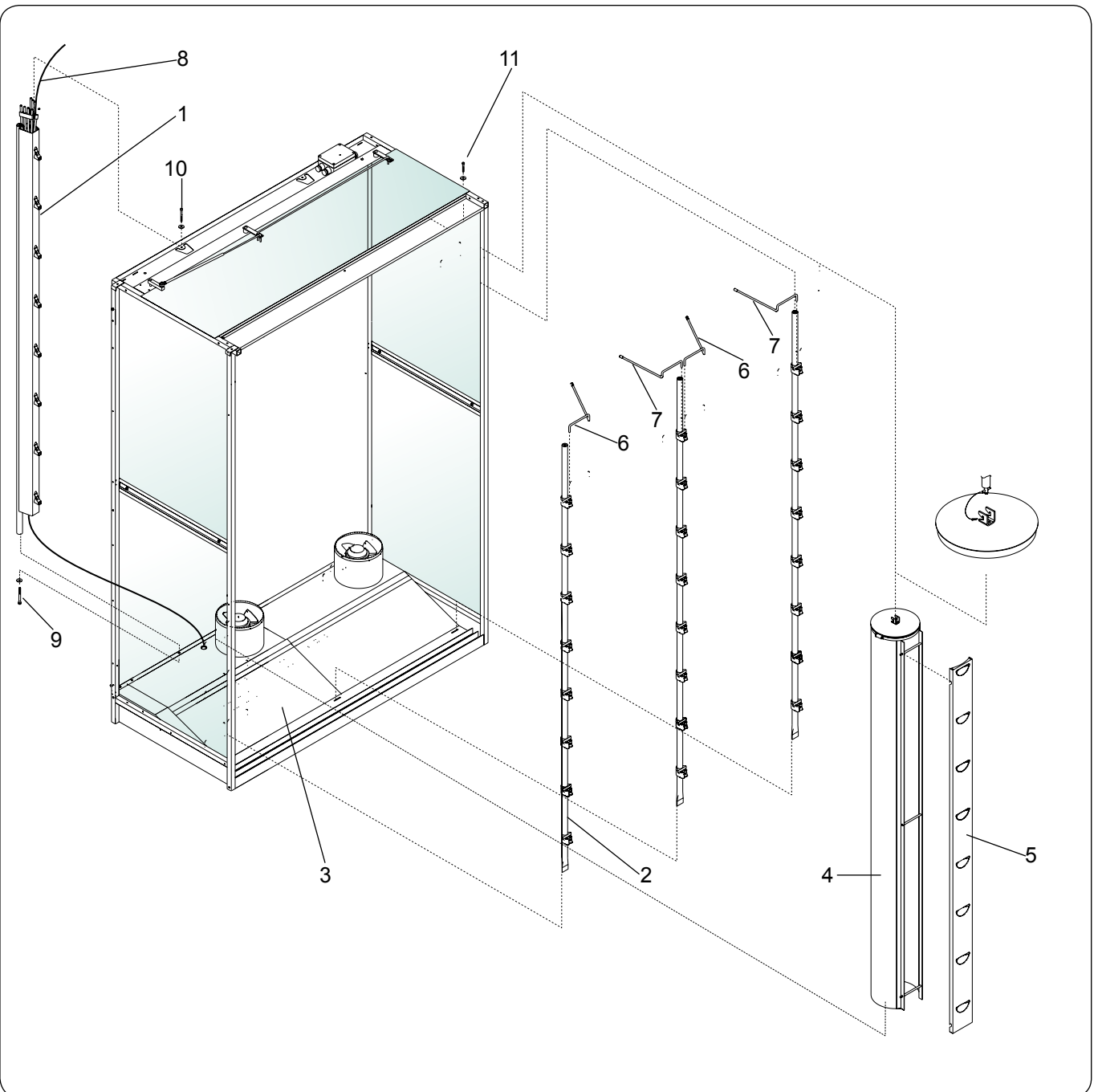

Creel

- ▶ Screw on yarn input carrier (1) at top and bottom.
- ▶ Insert package holder support (2) into the bottom of the door rail (3) and screw onto the top section.
- ▶ Run air hoses (4) over the fan units and insert into the support mounting at the top.
- ▶ Hang the shield (5) onto the air hoses.
- ▶ Fit package holders (6 and 7).
- ▶ Insert cable (8) into the tube channel.
- ▶ 1 cheese head screw, M6x40 and 1 washer A6.4 (9) per tube channel, bottom.
- ▶ 1 cheese head screw, M6x16 and 1 washer A6.4 (10) per tube channel, top.
- ▶ 1 cheese head screw, M6x16 and 1 washer A6.4 (11) per package holder.

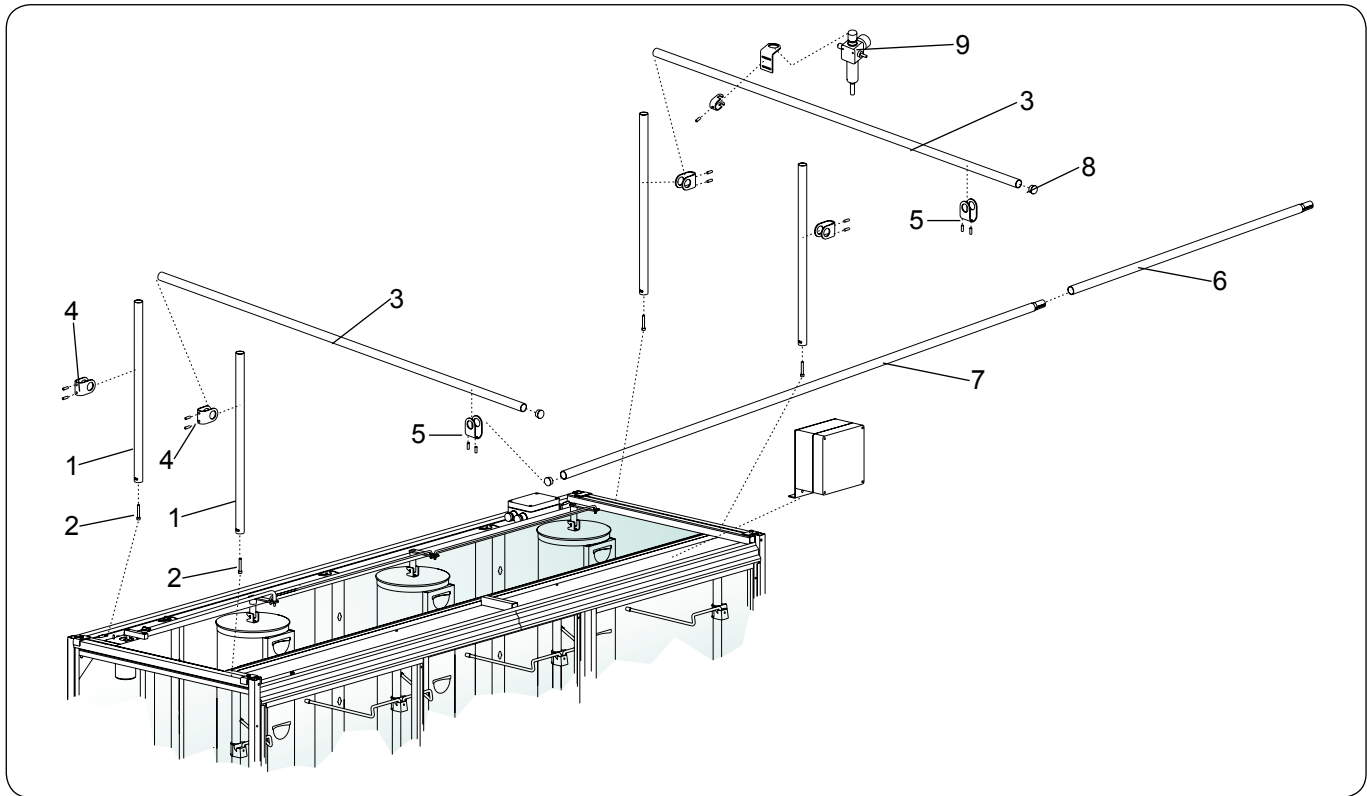

Tube support

- ▶ Fix support tube (1) with cheese head screw M6x40 (2) on the basic frame.
- ▶ Fasten the horizontal tube $\text{Ø}25 \times 1522$ (3) with bracket and cheese head screw M6x10 (4) onto the support tubes (1).
- ▶ Connect tube $\text{Ø}25 \times 570$ (6) with support tube (7), with bracket and cheese head screw (5) on the tubes (3).
- ▶ Fasten plugs (8) on the pipes.
- ▶ Fit filter pressure regulator (9) (Option) on the cross tube of the tube support.

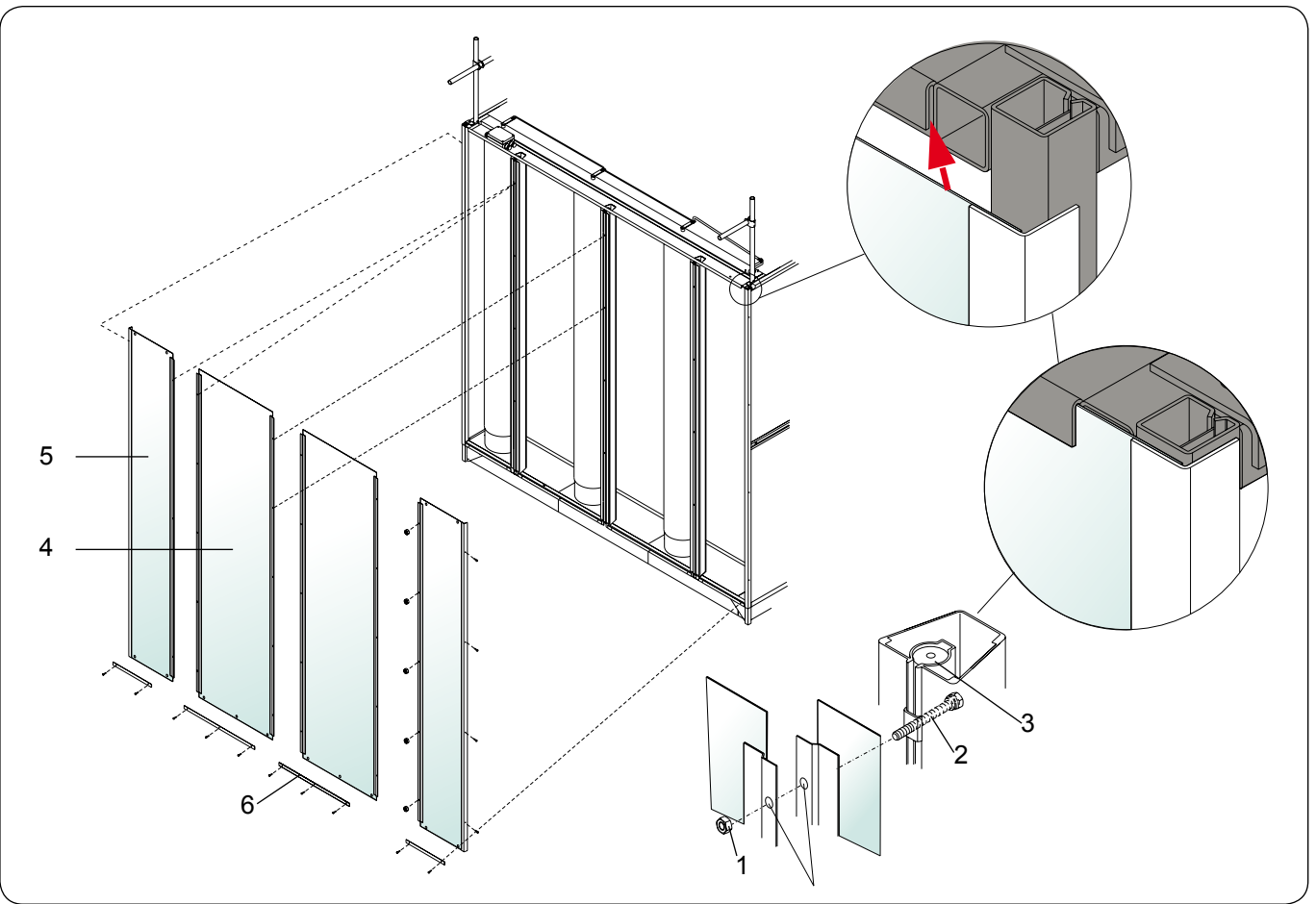

Backplate

- ▶ Unscrew the nuts (1) from the yarn input carrier (3).



NOTE!
Leave the clamping plates in position.



ATTENTION!
Ensure that the bore of the yarn input support and the foil bar are aligned. Otherwise it is not possible to assemble correctly.

- ▶ Insert the backplate segments (4) individually from the bottom in the slot of the roof.
- ▶ Tighten the narrow side piece (5) with self-tapping screws onto the side bars.
- ▶ Tighten the bottom rail (6) with self-tapping screws.

Door assembly

Screw the extension rail (1) onto the Creel cover.

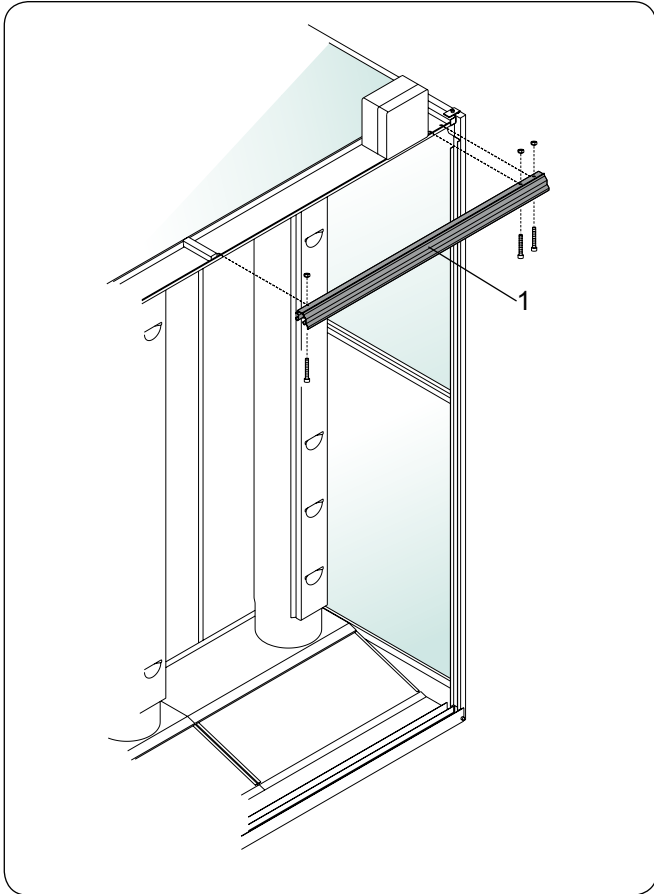

Hang in **all** doors (2) into the guides (1+3) at the top and bottom.

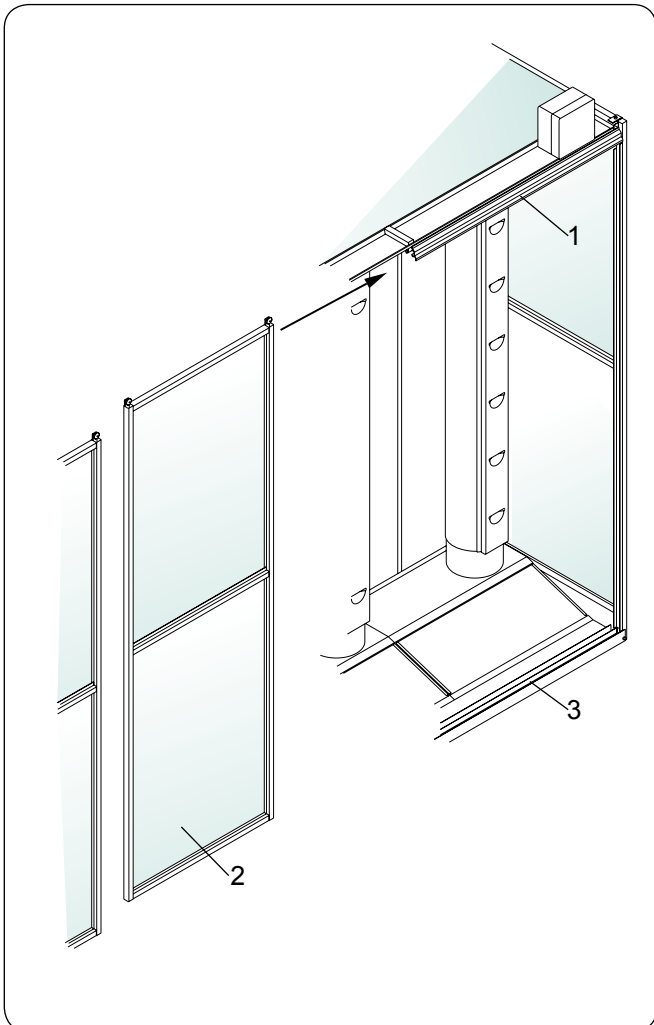

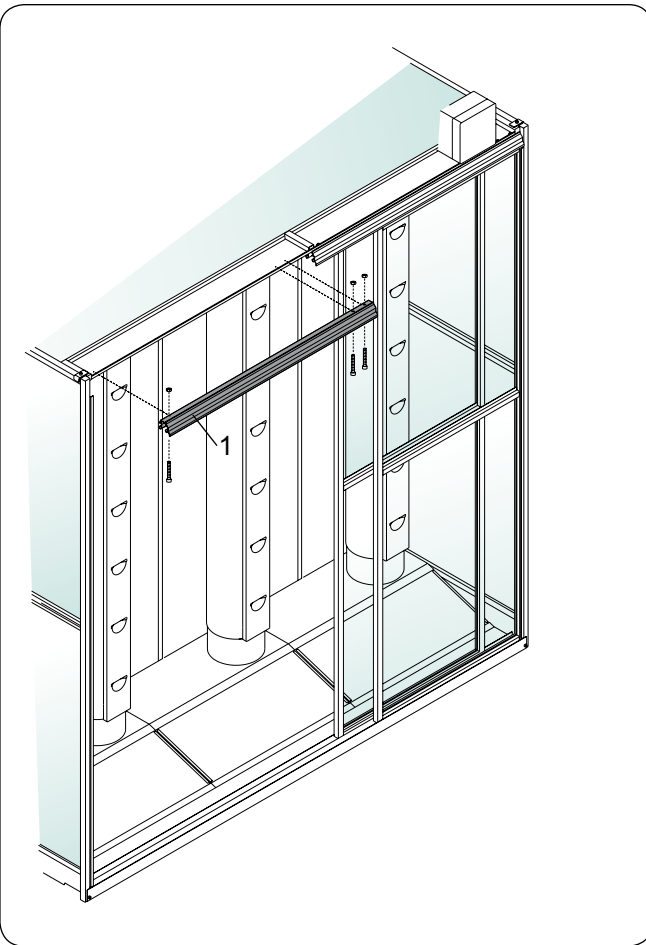

Screw down the basic rail (1) on the cover.

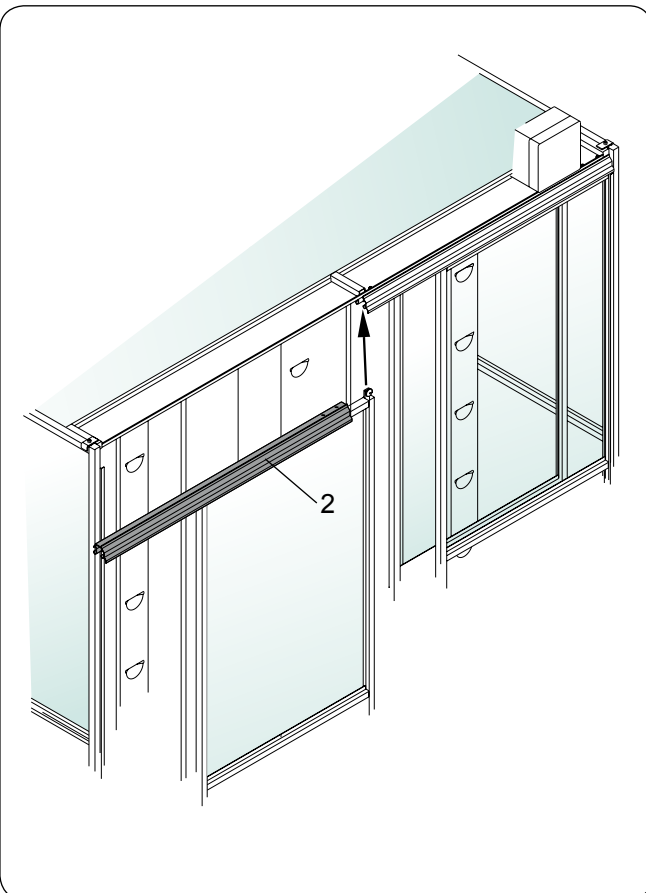

ATTENTION!

An exception. With the Creel comprising 2 or 3 segments, the last door must be hung into the extension rail (2) before it can be mounted together with the door to the cover.

Placing the yarn tubes

For plastic tubes

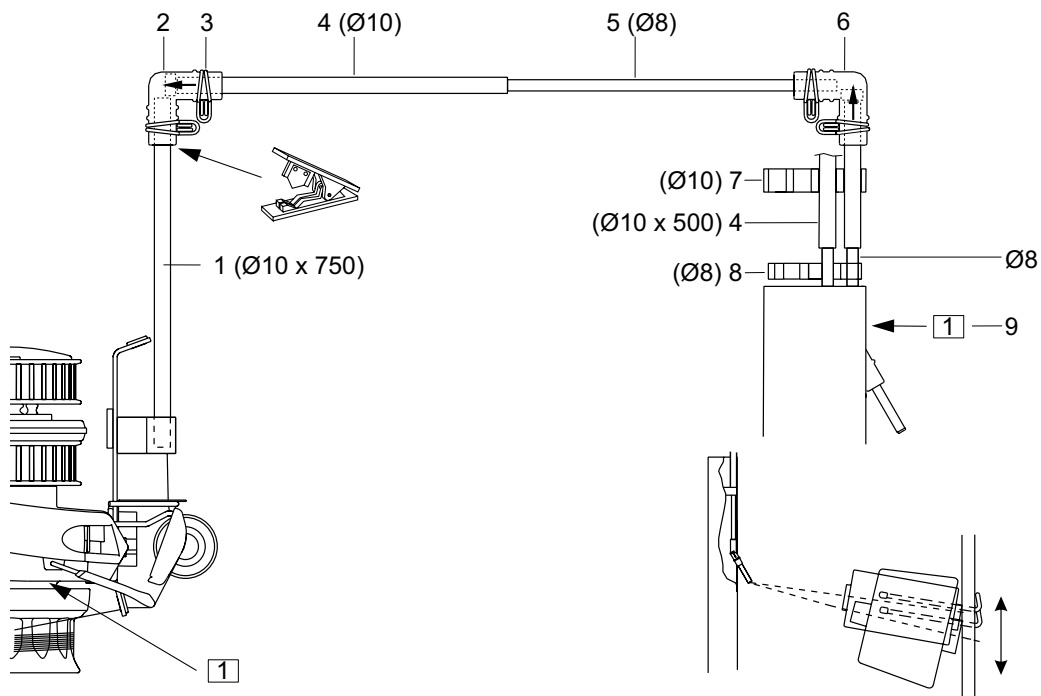

For aluminium tubes

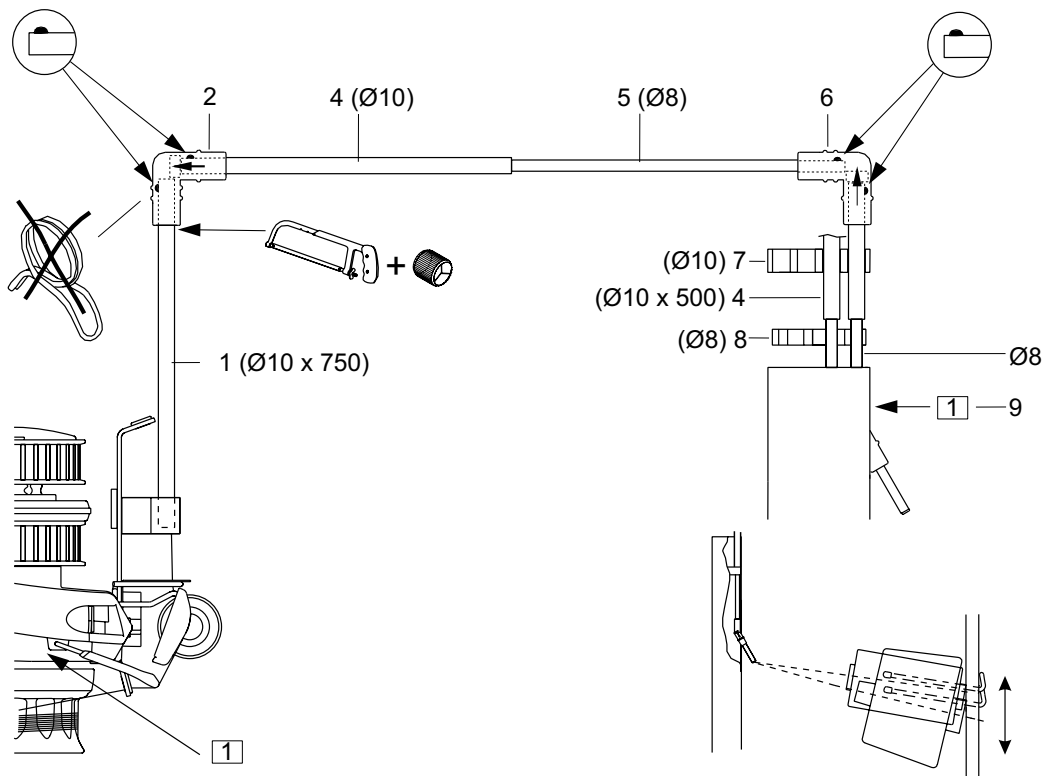

- 1* - aluminium tube Ø10 with collar eyelet 4,5
plastic tube Ø10 with collar eyelet 4,5
- 2 - angle Ø10
- 3 - wire clip
- 4* - aluminium tube Ø10
plastic tube Ø10

- 5* - aluminium tube Ø8
plastic tube Ø8
- 6 - angle Ø10-Ø8
- 7 - terminal strip Ø10
- 8 - terminal strip Ø8
- 9 - set system numbers

Air-Jet

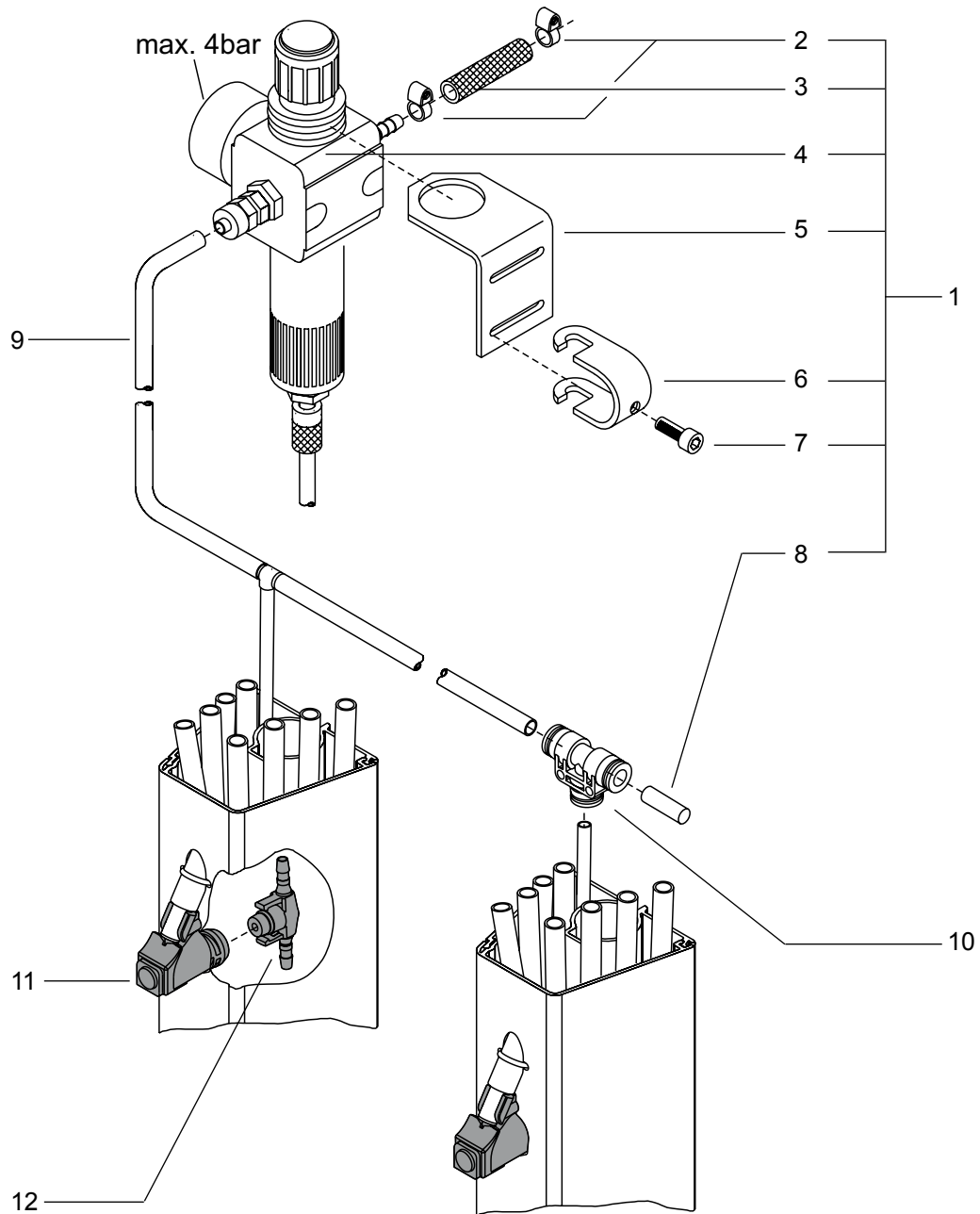

- 1 - filter pressure regulator R 1/4" for round pipe
incl. fastening, feed pipe and locking cap
- 2 - hose strap with screw 8-16
- 3 - braided hose Ø11x2,5 LW6
- 4 - filter pressure regulator R1/4" with automatic condensate drain
- 5 - holder, curved
- 6 - bracket
- 7 - cheese head screw M6x16
- 8 - locking cap 8/6
- 9 - hose 8x6
- 10 - T-reducing socket
- 11 - valve body for Air-Jet
- 12 - T-connector Air-Jet

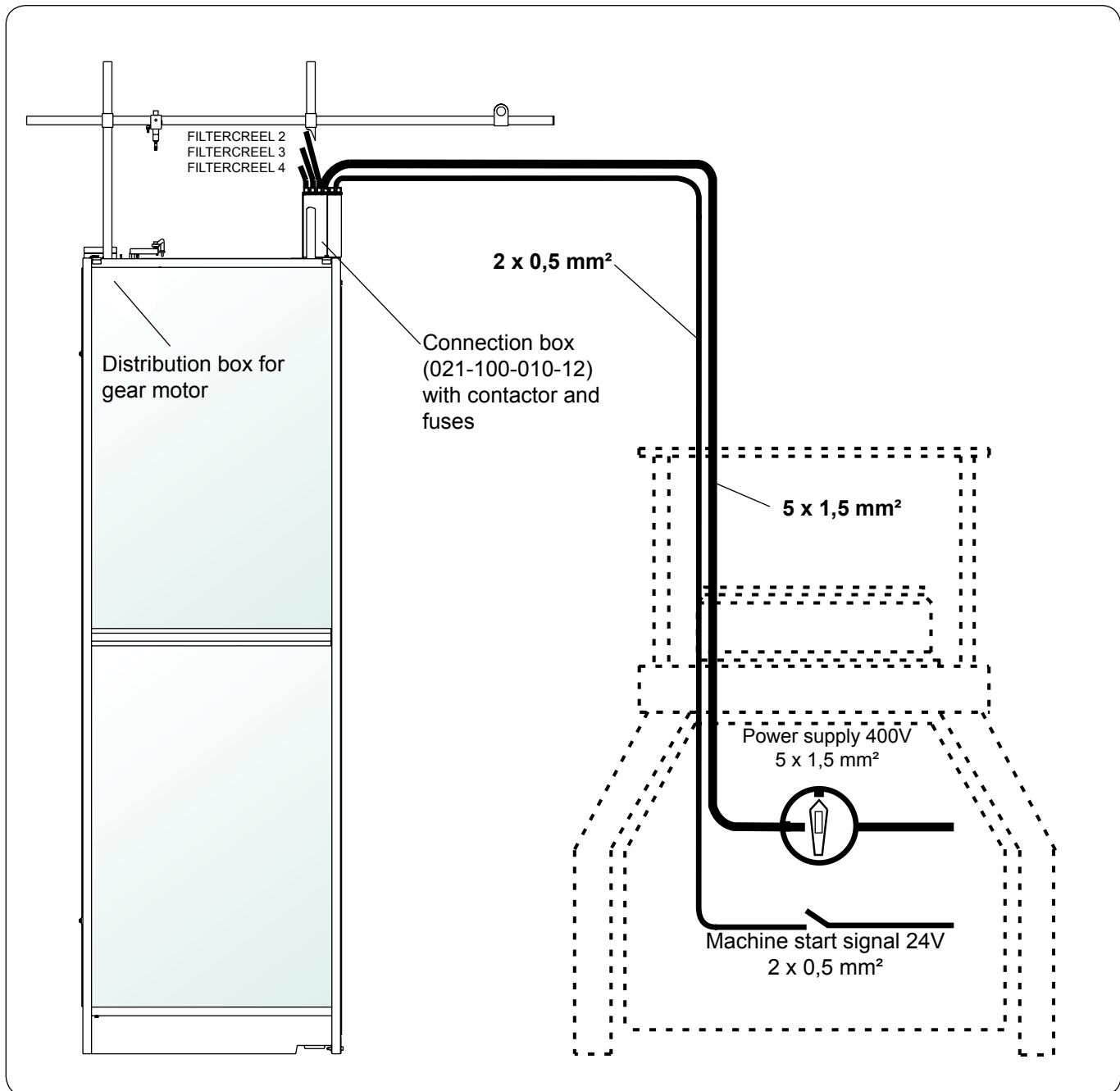

ATTENTION!

Connection of the FILTERCREEL and all work on the electrical system may only be carried out by a qualified electrician, in accordance with electrical engineering standards.

The 400 V AC 3 phase power supply comes from the machine and it must be possible to turn it off using the knitting machine's main switch. No voltage must be present in the connection box when the knitting machine is turned off.

A 24V control voltage is required to operate the FILTERCREEL. This control voltage may only be present when the machine is running.

The housing cover of the power supply must be closed at commissioning.

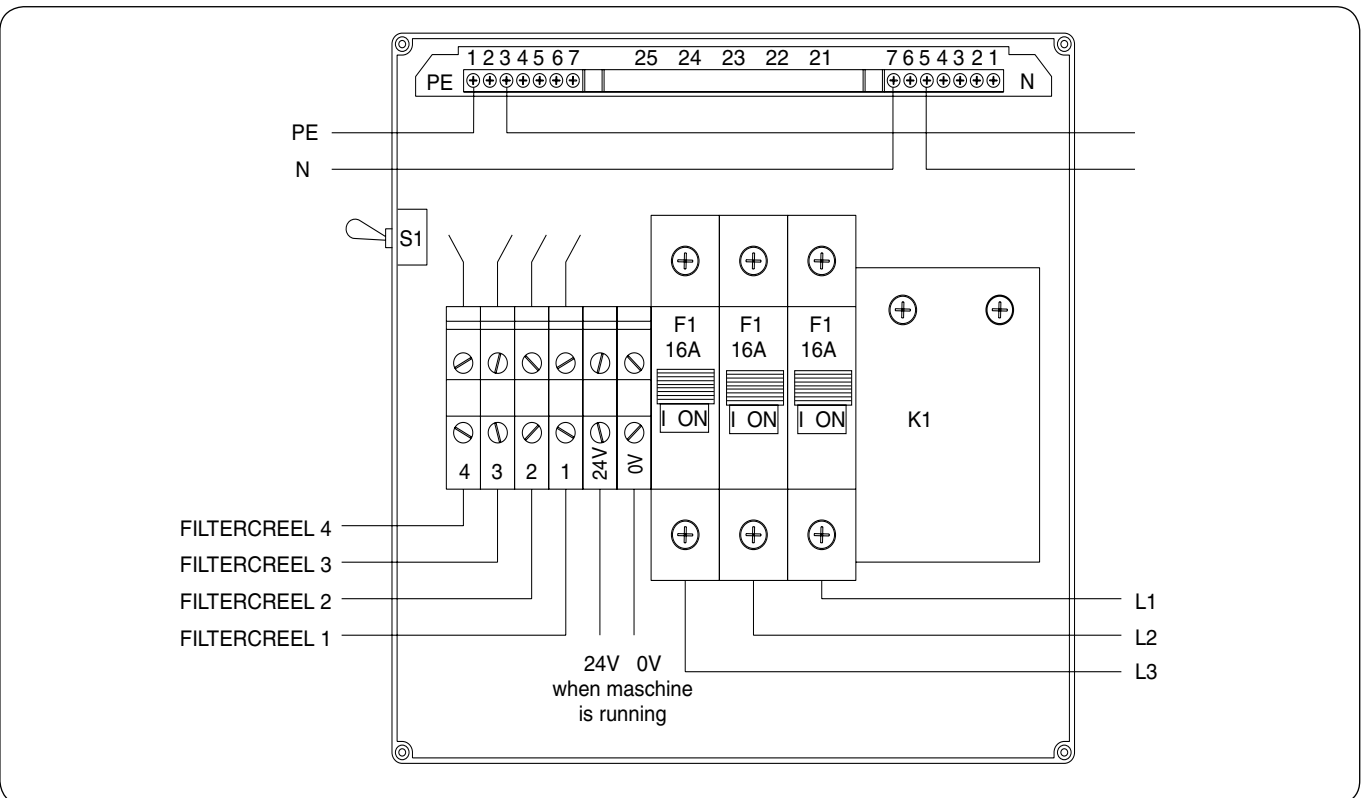

One connection box (021-100-010-12) is required for each knitting machine. The 400 V AC 3 phase power supply comes from the circular knitting machine and it must be possible to turn it off using the knitting machine's main switch. No voltage must be present in the connection box when the knitting machine is turned off.

A maximum of 4 FILTERCREEL devices may be connected to the connection box.

To operate the FILTERCREEL, a 24V start signal from the knitting machine is required. This start signal can only be present when the machine is running.

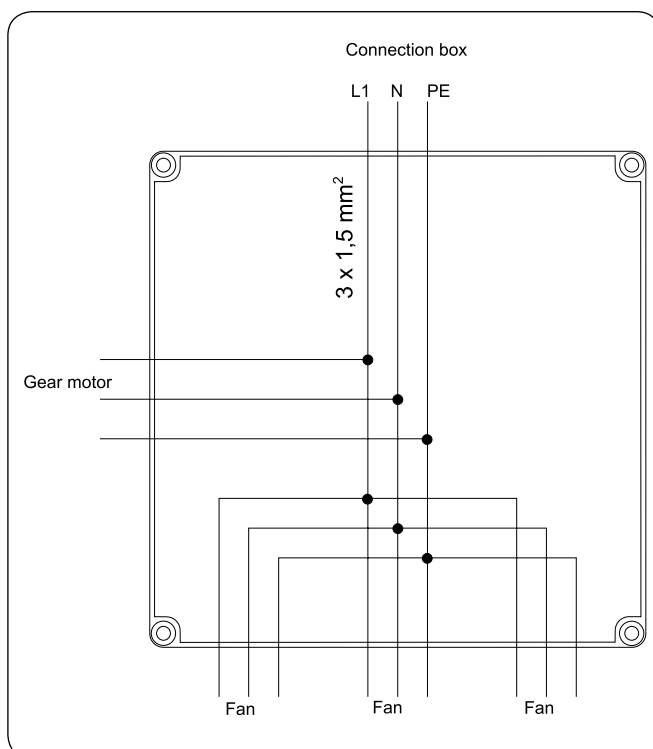

- ▶ Mount distribution box on the left-hand side piece using 4 M3x10 screws.
- ▶ Run the 3 x 1.5 mm² connecting cable to connection box 3 and run the gear motor power cable through the cable duct to the distribution box.
- ▶ Connect all ventilators and the gear motor in the distribution box. Connect the individual cables using insulating screw joints.

Power supply:

230 V 50 Hz

Maximum current consumption:

2 segments: 1,64 A
3 segments: 2,46 A
4 segments: 3,28 A
5 segments: 4,10 A
6 segments: 4,92 A

Weight:

2 segments: 150 kg
3 segments: 260 kg
4 segments: 310 kg
5 segments: 350 kg
6 segments: 410 kg

Dimensions:

Height: 2350 mm (top edge of FILTERCREEL)

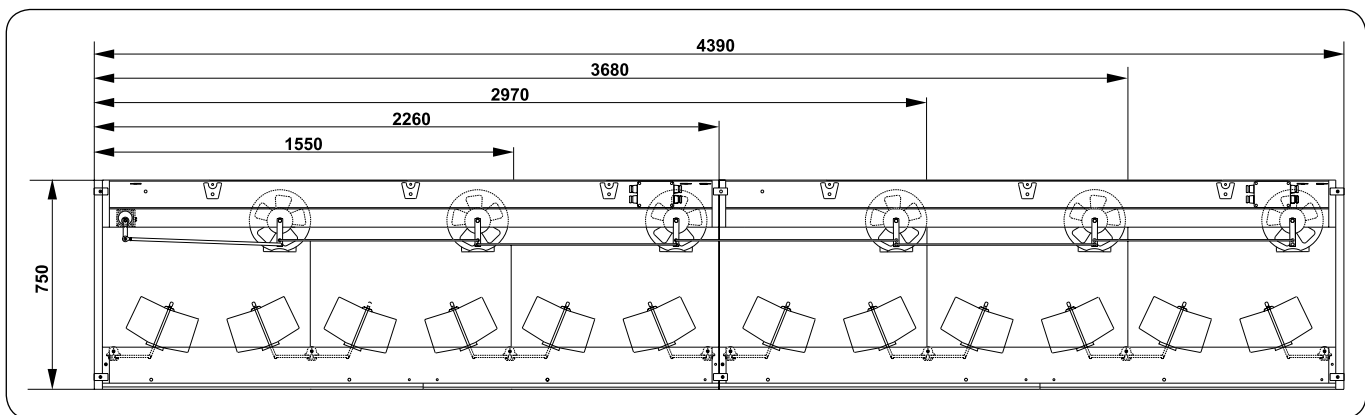

Declaration of incorporation

In conformity with EU Machinery Directive 2006/42/EC, Annex II B
In conformity with the EU Low Voltage Directive 2006/95/EC

also

Declaration of conformity

In conformity with the EU Electro Magnetic Compatibility (EMC) Directive, 2004/108/EC

The manufacturer: Memminger-IRO
Jakob-Mutz-Straße 7
72280 Dornstetten, Germany

hereby certifies that the following subassembly

Product name: FILTERCREEL 3

conforms to the requirements of the above named directives.

The subassembly is supplied complete with an original instruction manual and original technical documentation.

The subassembly may not be put into service until the machinery into which it is to be incorporated has been declared as being in conformity with the provisions of the EU Machinery Directive 2006/42/EC, Annex II A.

Dornstetten, 10.02.2010



M. Kleindorp, Company Management

MEMMINGER-IRO GmbH
Postfach 1240
72277 Dornstetten - Germany
Jakob-Mutz-Straße 7
72280 Dornstetten - Germany

Tel.: +49 7443 281-0
Fax: +49 7443 281-101
E-Mail: info@memminger-iro.de
Internet: www.memminger-iro.de